

# 锂混线性动力电池包产品规格书

LFP-SODIUM HYBRID BATTERY PACK Product Specification

产品名称 / Name: 锂混线性动力电池包      产品型号 / Model: BN 6020 - BA

额定电压 / Rated Voltage: 60V      额定容量 / Rated Capacity: 20Ah



# 概述 / OVERVIEW

60V20Ah 锂混线性动力电池包

60V20Ah LFP-SODIUM HYBRID BATTERY PACK



## 平稳动力 / Smooth Power

铅酸替代，钠锂混联，线性输出，告别动力突变，畅享平顺骑  
Smooth Power, Lead-acid Replacement, Sodium-ion Technology, Linear Output, Say Goodbye to Sudden Power Changes, and Enjoy Smooth Riding.

## 经久耐用 / Ultra-long Lifespan

循环寿命长，持久耐用，告别频繁更换，骑行更省心  
Long cycle life, durable and long-lasting, say goodbye to frequent replacements, enjoy worry-free riding.

## 智能守护 / Intelligent Guardian

定制BMS系统，多重安全防护，保障电池稳定运行  
Customized BMS, multiple safety protections, ensuring stable battery operation.

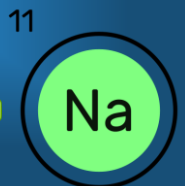

11

# 技术规格 / TECHNICAL SPECIFICATIONS

	序号 /No.	项目/Item	参数/Parameter	备注/Remark
电池组 /Pack	1	组合方式 Combination method	19S	9S钠电芯 + 10S铁锂电芯 NaCR32140-MP10 钠电芯 (中科海钠) IFP2265146-21Ah 锂离子电芯 (国轩高科)
	2	额定容量 Rated Capacity	标称/Typical 20Ah	标准充电后标准放电 (针对电池组) Standard discharge after Standard charge
	3	额定电压 Rated Voltage	60V	
	4	放电截止电压 Discharge Cut-off Voltage	44.5V	铁锂单体电芯2.65V, 钠单体电芯2.0V Cell
	5	充电截止电压 Charge Cut-off Voltage	72.05V	铁锂单体电芯3.65V, 钠单体电芯3.95V Cell
	6	建议充电电流 Standard charge	2A~5A	0.1C~0.25C
	7	峰值电流 Peak Current	60 A	1-2S 保护切断

# 技术规格 / TECHNICAL SPECIFICATIONS

序号 /No.	项目/Item	参数/Parameter	备注/Remark
8	最大 (持续) 充电电流 Maximum Charge Current	10A	0.5C
9	最大 (持续) 放电电流 Maximum Discharge Current	40A	2C
10	工作温度范围 Operation Temperature Range	充电 Charge 0°C~55°C 放电 Discharge -20°C~60°C	单体电芯储存湿度范围 < 75% R.H. Bare Cell
11	内阻 Internal Impedance	< 100mΩ	半电态下用交流法测量内阻 Internal resistance measured at AC 1KHZ after 50% charge
12	重量 Weight	12.8Kg	未灌胶
13	尺寸 Dimensions	160×180×346 (mm)	
14	循环寿命 Cycle life	1200次	常温测试, 0.5C充至满电, 搁置30min, 以0.5C放电至截止电压, 搁置30min, 循环至剩余容量不低于额定容量的80%

# 外观结构 / CASE STRUCTURE OF BATTERY PACK

充放电接口（兼容铅酸、  
锂电充电器）

液晶显示屏（电量、电压、  
电流等即时显示）

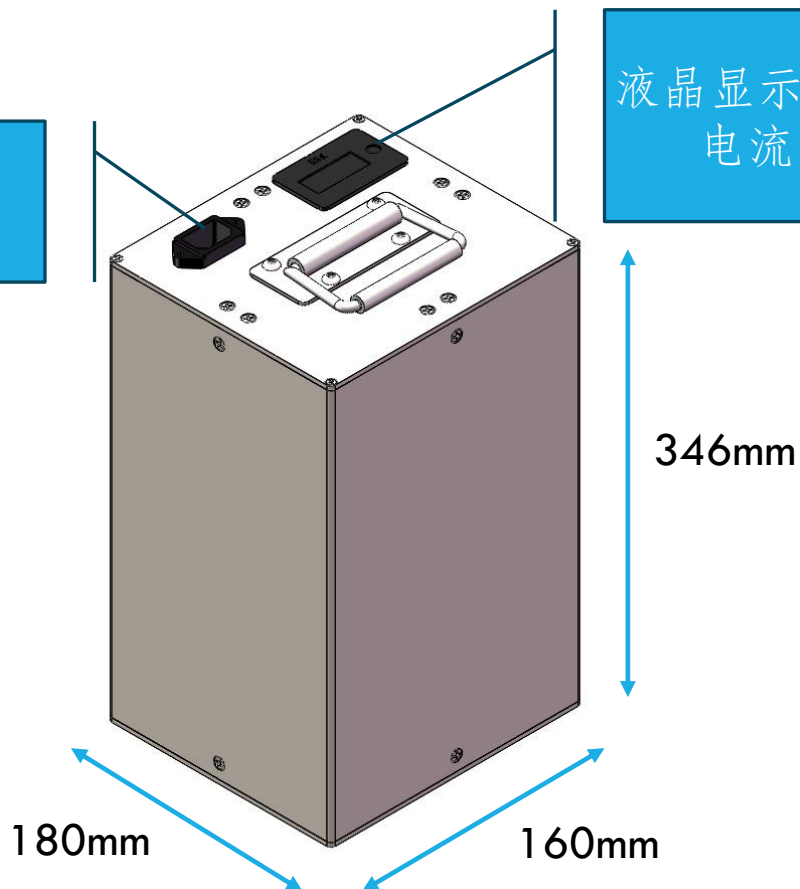

# 外观结构 / CASE STRUCTURE OF BATTERY PACK

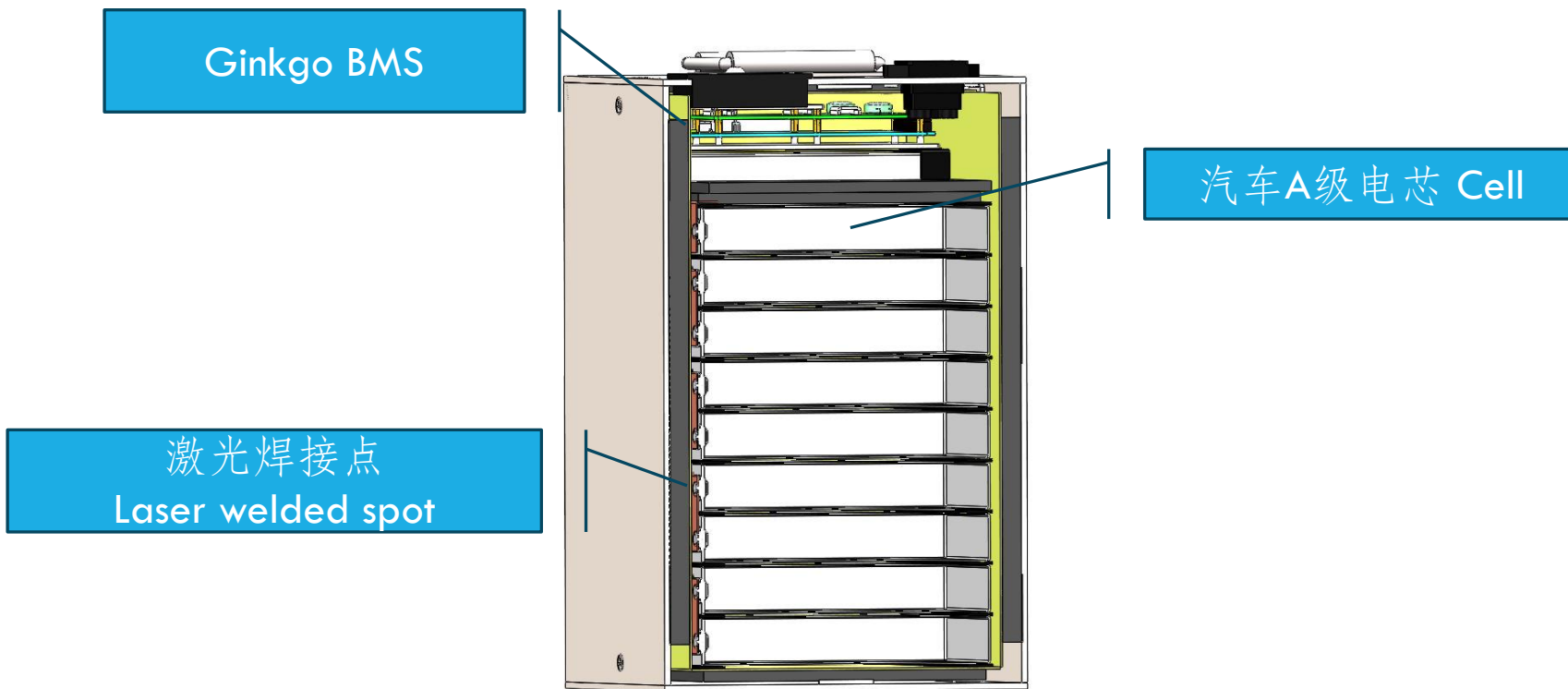

# 安全特性 / SAFETY FEATURES

## 银杏BMS系统 / Ginkgo BMS

过充电保护功能 / overcharge detection function

过放电保护功能 / over discharge detection function

过电流保护功能 / over current detection function

短路保护功能 / short detection function

温度保护功能 / Temperature detection function

均衡功能 / balance function

通讯功能 / communicate function

告警功能 / Alarm function

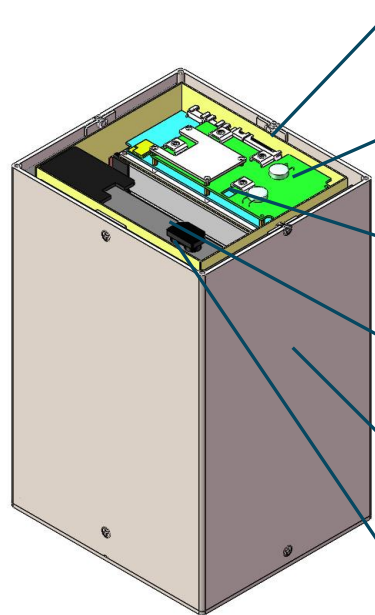

Ginkgo BMS

蓝牙防盗

电池护照

电芯汽车级方壳封装

铝合金外壳

内部整体灌胶

# 安全特性 / SAFETY FEATURES

BMS系统双重保护：

电池保护板采用熔断丝+高速MOS开关设计，提供过压、过流、短路、过温的双重开关保护。

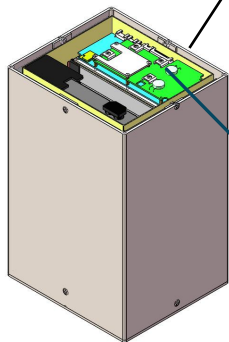

Ginkgo BMS

