

磷酸铁锂电池包产品规格书

LiFePO₄ Battery Pack Product Specification

产品名称 / Name: 磷酸铁锂电池包

产品型号 / Model: BF6020-BA

额定电压 / Rated Voltage: 60V

额定容量 / Rated Capacity: 20Ah



概述 / OVERVIEW

60V20Ah磷酸铁锂电池包

60V20Ah LiFePO4 Battery Pack



极致安全 / Ultimate Safety

磷酸铁锂技术，大厂A级电芯，整体灌胶，稳定可靠，安全无忧
LiFePO4 technology, Potting, stable and reliable, worry-free safety

智能掌控 / Intelligent Control

银杏BMS系统，强大性能监控与优化
Ginkgo BMS, powerful performance monitoring and optimization

持久动力 / Enduring Power

长期陪伴您的每次旅程
accompanying your journeys for years to come

技术规格 / TECHNICAL SPECIFICATIONS

	序号 /No.	项目/Item	参数/Parameter	备注/Remark
电池组 /Pack	1	组合方式 Combination method	19S	IFP2265146-21Ah 锂离子电芯 (国轩高科)
	2	额定容量 Rated Capacity	标称/Typical 20Ah	标准充电后标准放电 (针对电池组) Standard discharge after Standard charge
	3	额定电压 Rated Voltage	60V	
	4	放电截止电压 Discharge Cut-off Voltage	50.35V	单体电芯2.65V Cell
	5	充电截止电压 Charge Cut-off Voltage	69.35	单体电芯3.65V Cell
	6	建议充电电流 Standard charge	2~5A	0.1C~0.25C
	7	峰值电流 Peak Current	60A	5S后保护切断

技术规格 / TECHNICAL SPECIFICATIONS

	序号 /No.	项目/Item	参数/Parameter	备注/Remark
电池组 /Pack	8	最大 (持续) 充电电流 Maximum Charge Current	10A	0.5C
	9	最大 (持续) 放电电流 Maximum Discharge Current	40A	2C
	10	工作温度范围 Operation Temperature Range	充电 Charge 0°C~55°C 放电 Discharge -20°C~60°C	单体电芯储存湿度范围 < 75% R.H. Bare Cell
	11	内阻 Internal Impedance	< 100mΩ	半电态下用交流法测量内阻 Internal resistance measured at AC 1KHZ after 50% charge
	12	重量 Weight	13.40Kg	
	13	尺寸 Dimensions	160×180×286 (mm)	
	14	循环寿命 Cycle life	1200	常温测试, 0.5C充至满电, 搁置30min, 以0.5C放电至截止电压, 搁置30min, 循环至剩余容量不低于额定容量的80%

外观结构 / CASE STRUCTURE OF BATTERY PACK

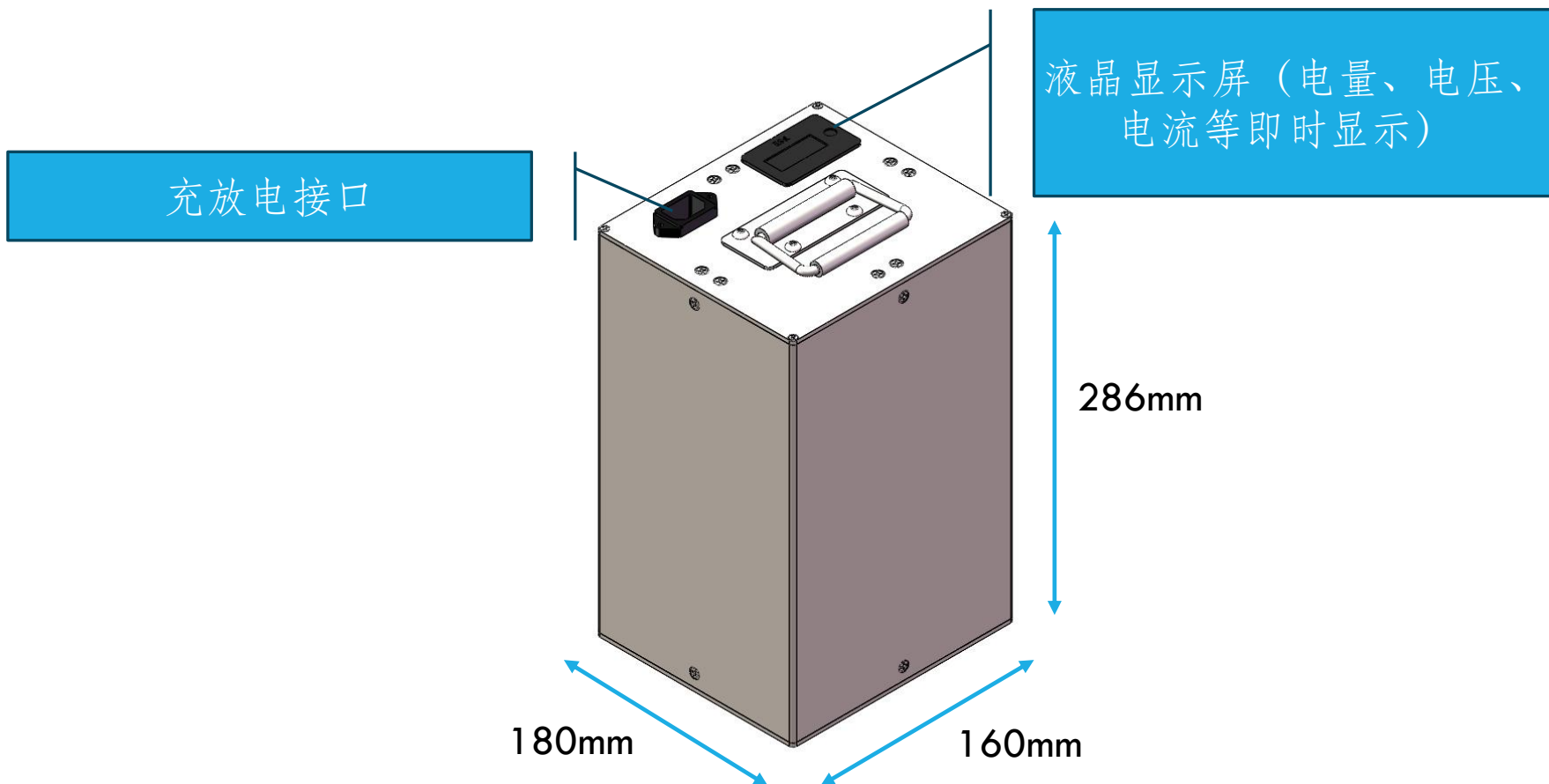

外观结构 / CASE STRUCTURE OF BATTERY PACK

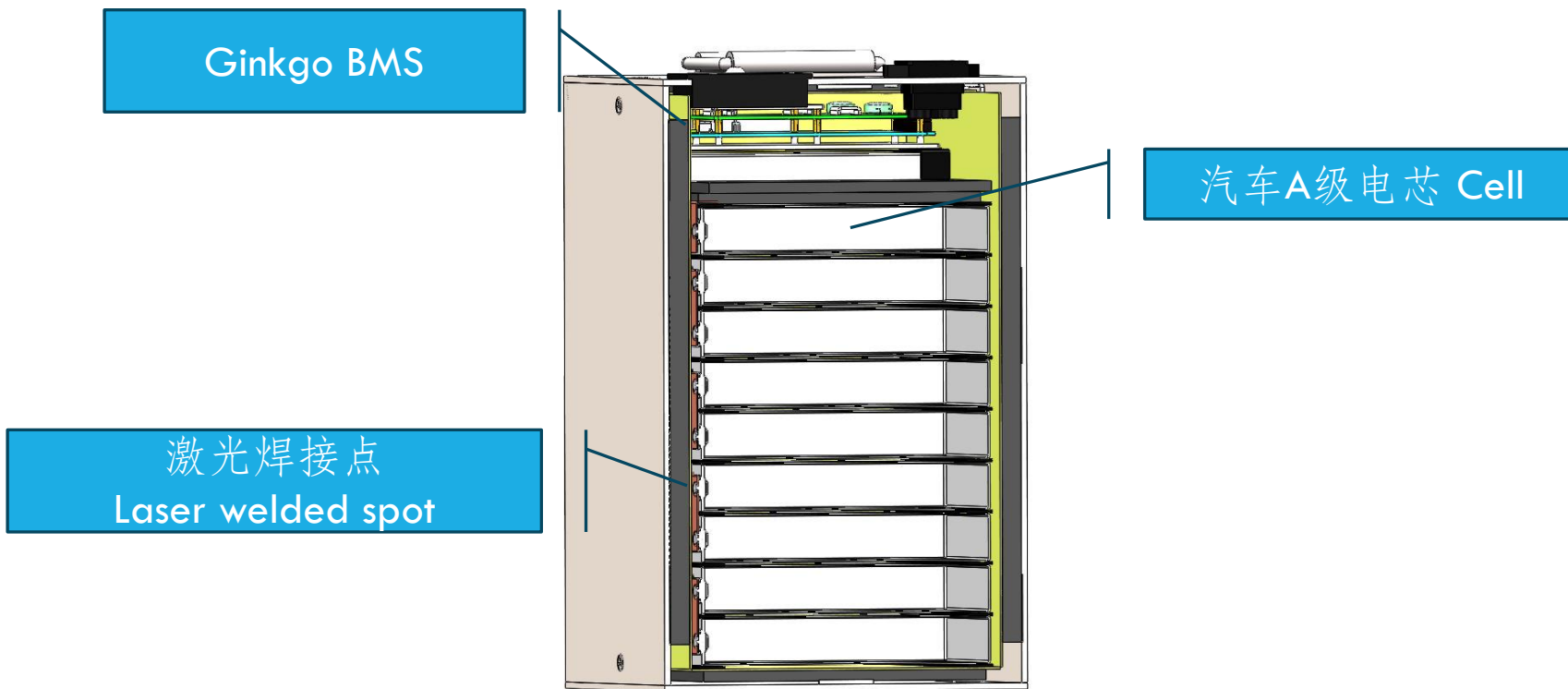

安全特性 / SAFETY FEATURES

银杏BMS系统 / Ginkgo BMS

过充电保护功能 / overcharge detection function

过放电保护功能 / over discharge detection function

过电流保护功能 / over current detection function

短路保护功能 / short detection function

温度保护功能 / Temperature detection function

均衡功能 / balance function

通讯功能 / communicate function

告警功能 / Alarm function

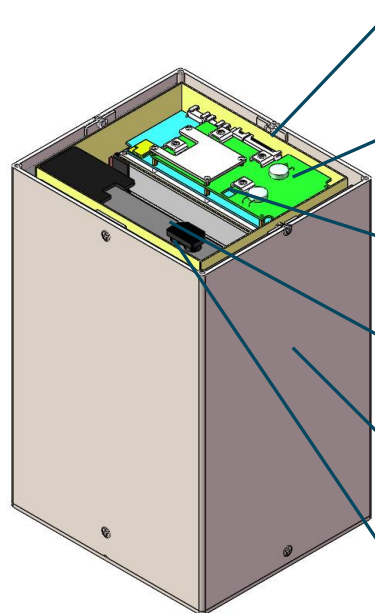

Ginkgo BMS

蓝牙防盗

电池护照

电芯汽车级方壳封装

铝合金外壳

内部整体灌胶

安全特性 / SAFETY FEATURES

BMS系统双重保护：

电池保护板采用熔断丝+高速MOS开关设计，提供过压、过流、短路、过温的双重开关保护。

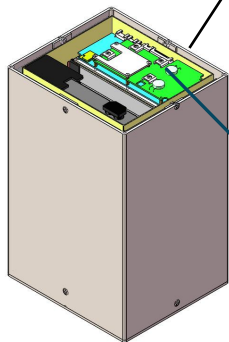

Ginkgo BMS

